

# OLYMPUS<sup>®</sup>

---

## INSTRUCTIONS



OLYMPUS ENDOSCOPY SYSTEM

MAINTENANCE UNIT

**MU-1**

**USA: CAUTION:** Federal law restricts this device to sale by or on the order of a physician.



# Contents

<b>Labels and Symbols .....</b>	<b>1</b>
<b>Important Information — Please Read Before Use.....</b>	<b>3</b>
Intended Use .....	3
Instruction Manual .....	3
User Qualifications .....	3
Instrument Compatibility.....	4
Repair and Modification .....	4
Signal Words .....	4
Dangers, Warnings and Cautions .....	5
<b>Chapter 1 Checking the Package Contents.....</b>	<b>6</b>
1.1 Checking the Package Contents.....	6
<b>Chapter 2 Instrument Nomenclature.....</b>	<b>7</b>
2.1 Instrument Nomenclature.....	7
<b>Chapter 3 Preparation and Inspection .....</b>	<b>9</b>
3.1 Preparation of the Equipment .....	9
3.2 Preparation and Inspection of the Maintenance Unit.....	11
3.3 Preparation and Inspection of the Endoscope and Disinfectant Container 15	15
<b>Chapter 4 Operation .....</b>	<b>17</b>
4.1 Leakage Testing .....	17
4.2 Remove water from the Air/Water Channel (For endoscope with Air/Water channel only) .....	18
<b>Chapter 5 Care, Storage and Disposal.....</b>	<b>20</b>
5.1 Care .....	20
5.2 Storage .....	21
5.3 Disposal .....	21
<b>Chapter 6 Troubleshooting .....</b>	<b>22</b>
6.1 Troubleshooting Guide.....	22
6.2 Returning the Maintenance Unit for Repair.....	23
<b>Appendix .....</b>	<b>24</b>
System Chart .....	24
Transportation, Storage and Operating Environments.....	26

Contents

Specifications ..... 26

# Labels and Symbols

Safety-related labels are attached to the instrument at the locations shown below. If labels are missing or illegible, contact Olympus.

## ○ Rear side

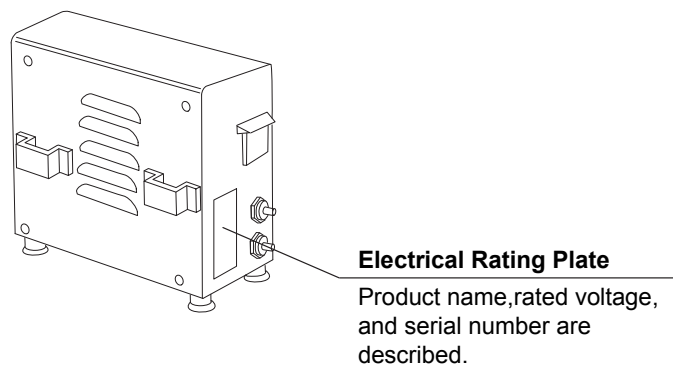

### Electrical Rating Plate

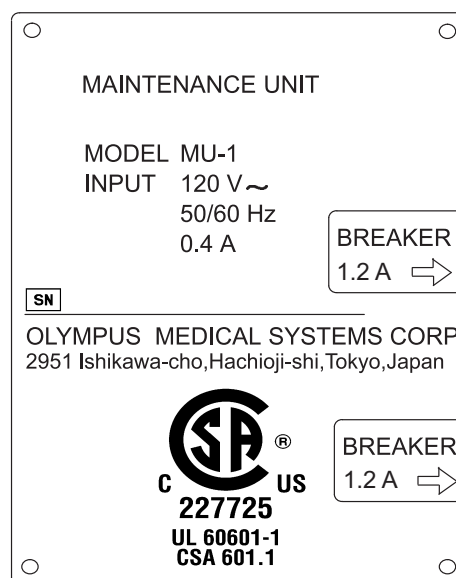

○ **Back cover of this instruction manual**



Manufacturer



Authorized representative in the European Community

# ***Important Information — Please Read Before Use***

## ***Intended Use***

This instrument has been designed to be used with an Olympus endoscope and other ancillary equipment for Leakage Testing and Remove water from the Air/Water Channel.

When combined with the optional MB-264 Disinfectant Container, the endoscope's Air/Water Channel can be irrigated with 70% ethyl or isopropyl alcohol to dry the channel.

Do not use this instrument for any purpose other than its intended use.

## ***Instruction Manual***

This instruction manual contains essential information on using this instrument safely and effectively. Before use, thoroughly review this manual and the manuals of all equipment which will be used during the procedure and use the instruments as instructed.

Keep this and all related instruction manuals in a safe, accessible location.

If you have any questions or comments about any information in this manual, please contact Olympus.

### **○ Terms Used in This Manual**

Wall Mains Outlet

An electrical outlet that has a terminal used exclusively for grounding.

## ***User Qualifications***

The operator of this instrument must be a physician or medical personnel under the supervision of a physician and must have received sufficient training in clinical endoscopic technique. This manual, therefore, does not explain or discuss clinical endoscopic procedures.

## ***Instrument Compatibility***

Refer to the “System Chart” in Appendix to confirm that this instrument is compatible with the ancillary equipment being used. Using incompatible equipment can result in patient or equipment damage.

## ***Repair and Modification***

This instrument does not contain any user-serviceable parts. Do not disassemble, modify or attempt to repair it; patient or user injury and/or equipment damage can result. If the problem appears minor, refer to Chapter 6, “Troubleshooting”.

If the problem cannot be resolved by using Chapter 6, contact Olympus.

## ***Signal Words***

The following signal words are used throughout this manual:

### **DANGER**

Indicates an imminently hazardous situation which, if not avoided, will result in death or serious injury.

### **WARNING**

Indicates a potentially hazardous situation which, if not avoided, could result in death or serious injury.

### **CAUTION**

Indicates a potentially hazardous situation which, if not avoided, may result in minor or moderate injury. It may also be used to alert against unsafe practices or potential equipment damage.

### **NOTE**

Indicates additional helpful information.



## ***Dangers, Warnings and Cautions***

Follow the dangers, warnings and cautions described below when handling this instrument. This information is supplemented by the dangers, warnings and cautions described in each chapter.

### **DANGER**

- Follow the following precautions strictly. Failure to do so may place the patient and medical personnel in danger of an electrical shock.
  - Keep liquids away from all electrical equipment. If spilled fluids enter the unit, stop operation of the equipment at once and contact Olympus.
  - Do not prepare, inspect or use this instrument with wet hands.
- Never use the Maintenance Unit in a flammable or high-concentration oxygen environment and keep all flammable gases and liquids or high-concentration oxygen away from the Maintenance Unit while it is being used. Explosion or fire may result because the instrument is not designed to be explosion-proof.
- Be sure to connect the Power Plug of the Power Cord directly to a grounded Wall Mains Outlet. If the Maintenance Unit is not grounded properly, it can cause an electric shock or/and fire.

### **WARNING**

Do not bend, pull or twist the Power Cord. Electrical shock, equipment damage or fire can result.

### **CAUTION**

- Alcohol is flammable. Handle with care.
- Do not connect the power cord of the MU-1 to a different voltage electrical outlet. Fire and smoke may result.

# Chapter 1 Checking the Package Contents

## 1.1 Checking the Package Contents

Match all items in the package with the components shown below. Inspect each item for damage. If the instrument is damaged, a component is missing or you have any questions, do not use the instrument; immediately contact Olympus.

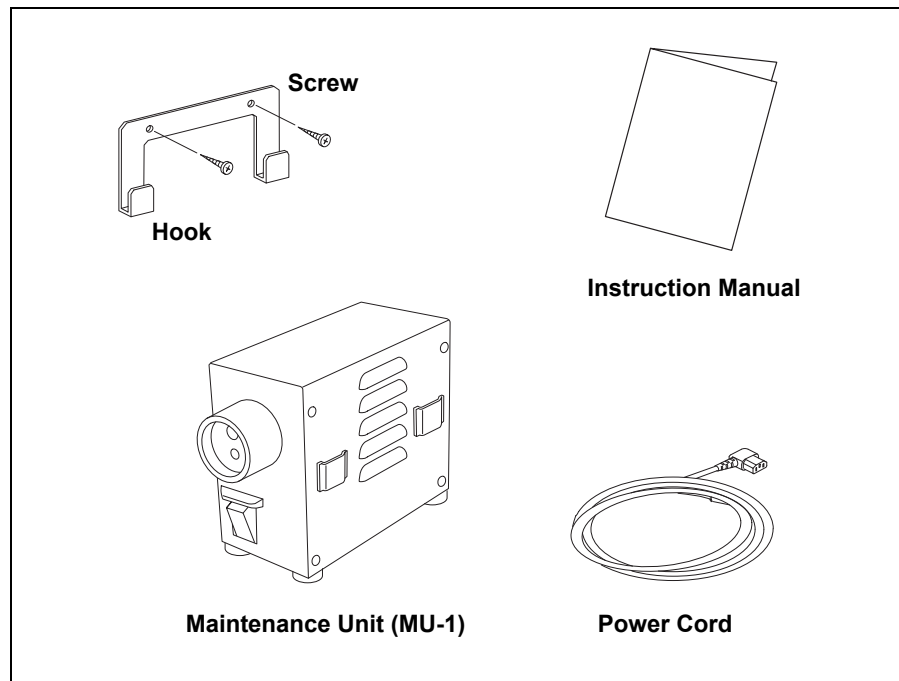

# Chapter 2 Instrument Nomenclature

## 2.1 Instrument Nomenclature

### Front Panel and Side Panel

#### Hook

Used to attach the Maintenance Unit to a wall. Use the screws to attach the Hook to a wall near a sink.

Screw ×2

#### Attachment Brackets (provided on both sides)

Attaches the Maintenance Unit to the hooks or attaches the MB-264 Alcohol Container to the Maintenance Unit. Brackets are provided on both sides of the unit.

#### Output Socket

Accepts the endoscope or leakage tester and feeds air.

#### Power Switch

Switches the power ON and OFF. The power switch lamp will illuminate and the unit emits air from the air pipe in the output socket when the power is on.

#### Ventilation Grills

Feet

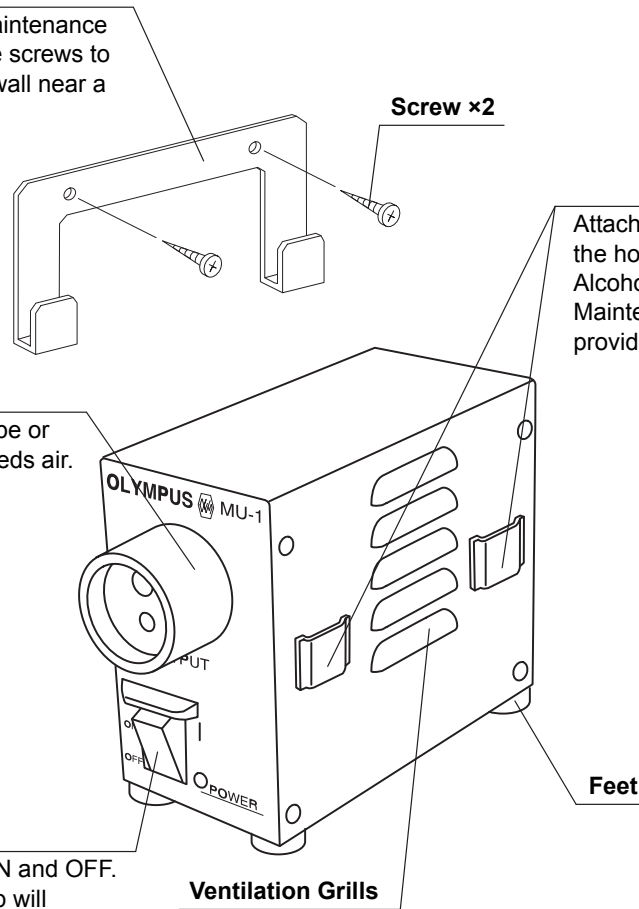

## Rear Panel

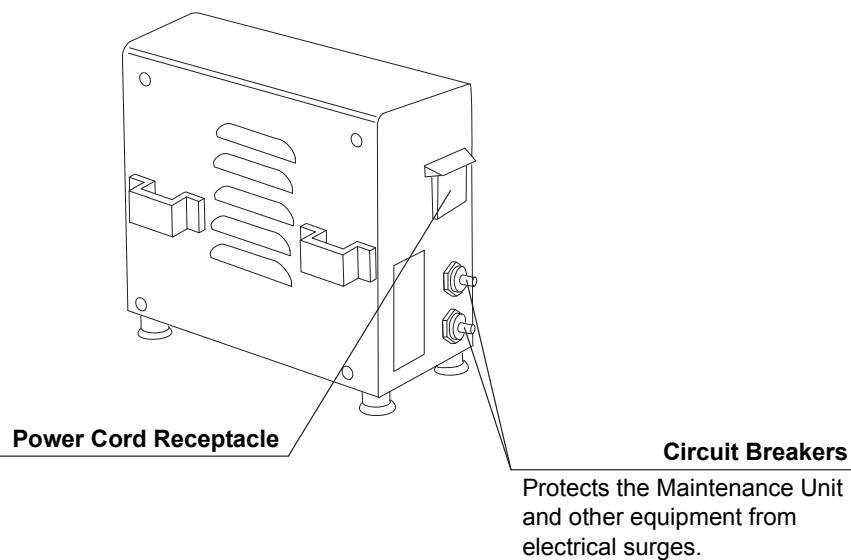

## Symbols and Descriptions

### ○ Power Switch

| ON

○ OFF

# **Chapter 3 Preparation and Inspection**

## **WARNING**

Before each case, prepare and inspect this instrument as instructed below. Inspect other equipment that are used with this instrument as instructed in their respective instruction manuals. Should the slightest irregularity be suspected, do not use the instrument and see Chapter 6, "Troubleshooting". If the irregularity is still suspected after consulting Chapter 6, contact Olympus.

Damage or irregularity may compromise patient or user safety and may result in more-severe equipment damage.

## **CAUTION**

Do not connect the power cord of the MU-1 to a different voltage electrical outlet. Fire and smoke may result.

According to the "System Chart" in the Appendix, prepare this instrument, other equipment that are used with this instrument, paper towels, basin, gauze and protective equipment, such as eye wear, a face mask, moisture-resistant clothing and chemical-resistant gloves, for the procedure.

Refer to the respective instruction manual for each piece of equipment.

## **3.1 Preparation of the Equipment**

### **WARNING**

Use 70% ethyl or isopropyl alcohol as directed on the container's label. Store 70% ethyl or isopropyl alcohol in an air-tight container. 70% ethyl or isopropyl alcohol stored in an open container may cause fires and will lose its efficacy due to evaporation.

### **CAUTION**

Use basins which are at least 40 cm by 40 cm (16" by 16") in size and deep enough to allow the endoscope to be completely immersed. Do not coil the endoscope's insertion tube or universal cord with a diameter less than 40 cm. The endoscope can be damaged if coiled too tightly.

Prepare the following equipment:

○ **Leakage Testing**

- Personal Protective Equipment
- Water Container
- Maintenance Unit (MU-1)
- Endoscope
- Leakage Tester (MB-155 Optional)
- Water-resistant Cap  
(provided with the endoscope,  
EVIS Videoscope only)

○ **Remove water from the Air/Water Channel (For endoscope with Air/Water channel only)**

- Personal Protective Equipment
- Maintenance Unit (MU-1)
- Endoscope
- AW Channel Cleaning Adapter  
(provided with the endoscope)
- Alcohol Container (MB-264 Optional)  
(only when irrigating with 70% ethyl  
or isopropyl alcohol)
- 70% ethyl or isopropyl alcohol  
(only when irrigating with 70% ethyl  
or isopropyl alcohol)

## **3.2 Preparation and Inspection of the Maintenance Unit**

### **WARNING**

Confirm that the Wall Mains Outlet that you connect the Maintenance Unit to has more capacity than the total power consumption of all connected equipment (including this Maintenance Unit). If the capacity is inadequate, fire can result or the Circuit Breaker may trip and turn OFF the Maintenance Unit and all other instruments connected to the same breaker.

### **CAUTION**

- Do not place the Maintenance Unit on its side or upside down.
- When installing the Maintenance Unit on the hooks, confirm that the screws which attach the hooks to the wall are not loose and that the Maintenance Unit is stable when attached to the hooks . When a hook comes off, the Maintenance Unit drops and is damaged, and there is a fear that a user hurt by the Maintenance Unit which dropped.
- The Maintenance Unit's Ventilation Grills should be clear of ancillary equipment. Blockage can cause overheating and equipment damage.
- Do not connect the power cord of the MU-1 to a different voltage electrical outlet. Fire and smoke may result.

## Installation

Install the Maintenance Unit on the Hook or place the unit on a stable surface in an area where the unit will not be exposed to the water splashed during operation. When installing the unit using the feet, confirm that the feet stick firmly to the installation surface, when attaching the unit to the Hook, confirm that the screws that attach the Hook to the wall are not loose, and that the Hook does not move when the unit is attached to it (see Figure 3.1).

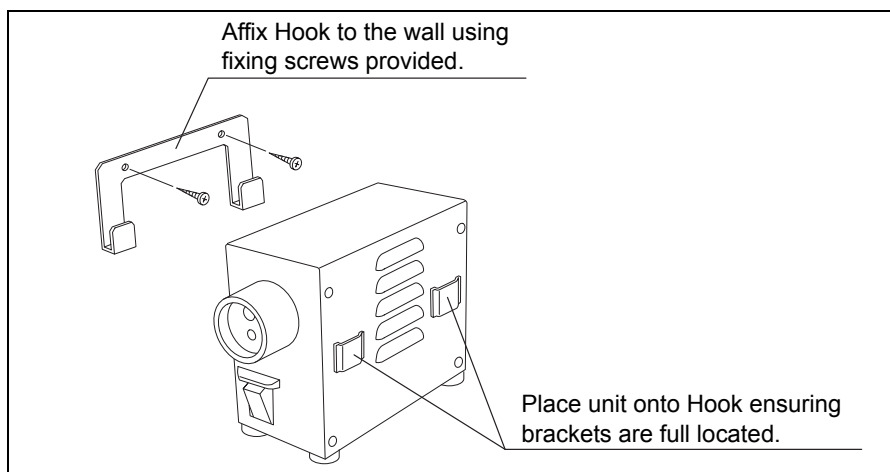

Figure 3.1

## Connecting the Power Supply

**NOTE**

The plug of the power cord that follows the equipment may vary from this drawing, as in each country the commercialized cable is in accordance to the local applicable norm.

1. Confirm the Power Switch is OFF “○”.
2. Connect the Power Cord to the Power Cord Receptacle.
3. Insert the other end of the Power Cord directly into a Wall Mains Outlet (see Figure 3.2).



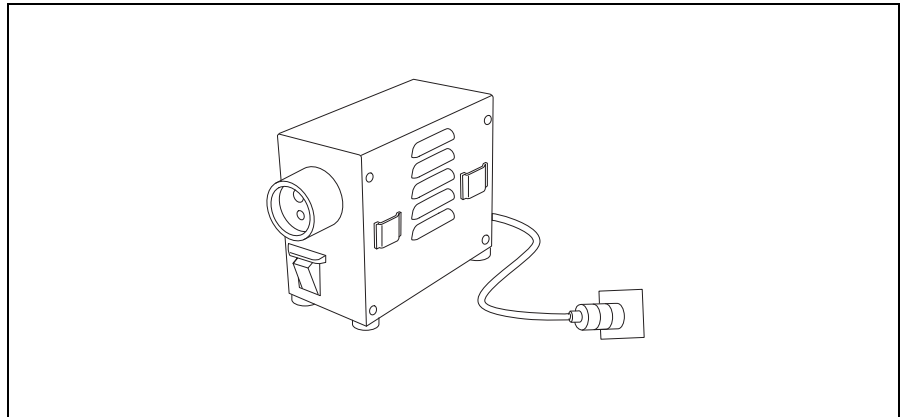

Figure 3.2

### ***Inspecting the Operation***

1. Turn the Power Switch ON “ I ”.
2. Confirm that the Power Switch lamp lights and that the pump starts operating.
3. Confirm that air comes out of the lower hole in the Output Socket (see Figure 3.3).
4. Turn the Power Switch OFF “ O ”.

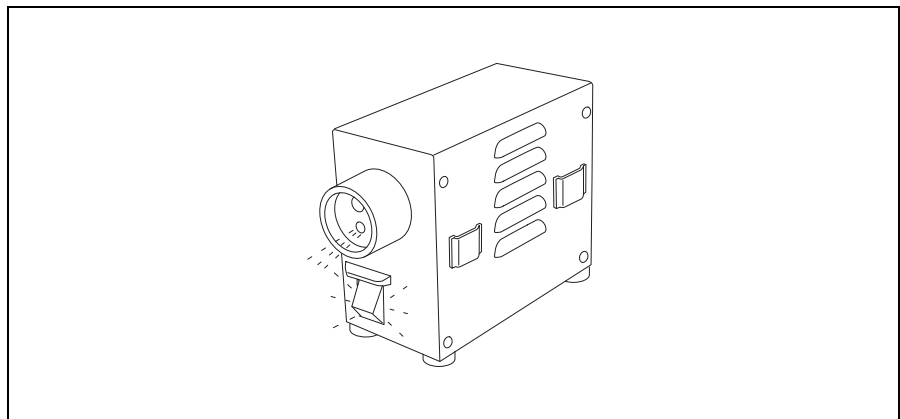

Figure 3.3

## ○ If Power Fails to Come on

If power fails to come on, inspect the system as follows:

1. Confirm that the Power Cord is connected securely to a Wall Mains Outlet and the Power Cord Receptacle on the Maintenance Unit.
2. Confirm that the Circuit Breakers have not tripped by checking that the breaker buttons have not popped up. If the buttons have popped up, reset the breakers according to the following procedure 3. and 4.

### **WARNING**

Reset the Circuit Breakers only once. If the power is still not supplied to the Maintenance Unit after resetting the Circuit Breakers, immediately turn the Power Switch OFF “○” disconnect the Power Cord from a Wall Mains Outlet and contact Olympus. This condition can result in electrical shock and/or fire.

### **CAUTION**

When the Circuit Breakers trips, do not reset the Circuit Breakers immediately. Turn the Power Switch OFF “○”. Wait at least 15 seconds before resetting the Circuit Breakers to prevent Circuit Breaker damage.

3. Turn the Power Switch OFF “○”, disconnect the Power Cord and depress the Circuit Breaker buttons until it stops with a click.
4. Reconnect the Power Cord and turn the Power Switch ON “|”. Confirm that power is being supplied to the Maintenance Unit.

### 3.3 Preparation and Inspection of the Endoscope and Disinfectant Container

**CAUTION**

The Fiberscope Adapter (AC10-S) is not waterproof. Ensure it is removed before immersing the OES Fiberscope in a solution.

#### **Leakage Testing**

Refer to the instruction manuals of the Leakage Tester and endoscope for directions on Leakage Testing.

#### **Remove water from the Air/Water Channel (For endoscope with Air/Water channel only)**

1. When using the OES Fiberscope, remove the Fiberscope Adapter from the Light Guide Connector (if used).
2. Remove the Air/Water Valve from the endoscope and replace it with the AW Channel Cleaning Adapter (see Figure 3.4).

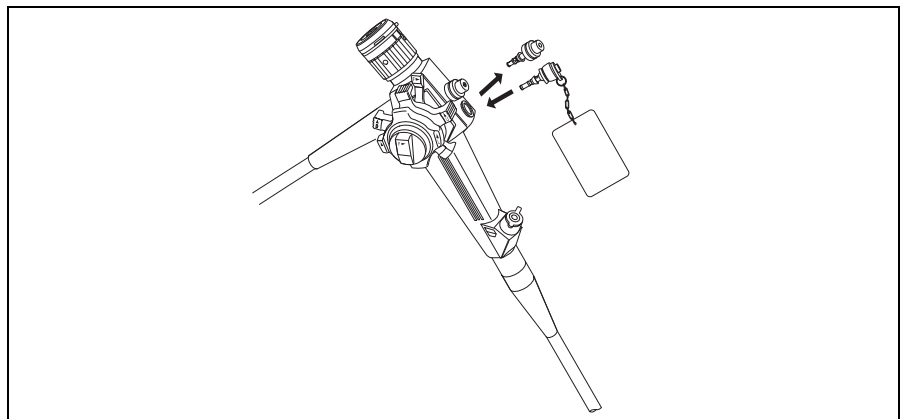

Figure 3.4

3. Insert the Light Guide Connector as far as it will go into the Output Socket on the front panel of the Maintenance Unit (see Figure 3.5).

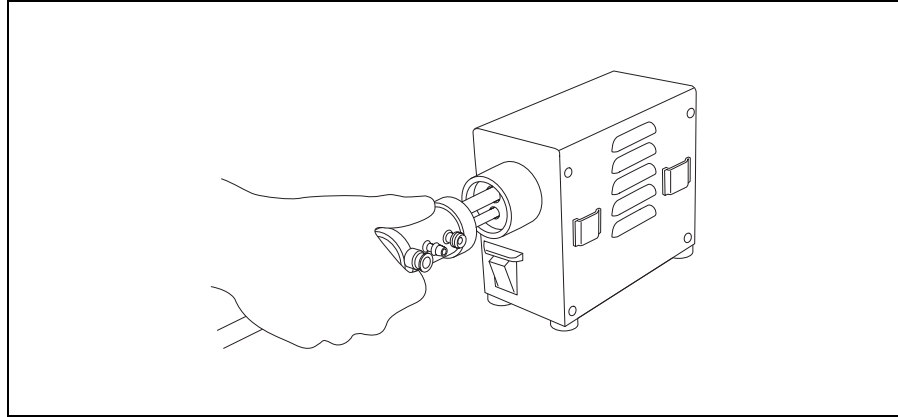

Figure 3.5

Perform the following procedures only when irrigating the channel with 70% ethyl or isopropyl alcohol. Operate to the Alcohol Container (MB-264) according to the directions given in its instruction manual.

4. Fill the Alcohol Container 70% ethyl or isopropyl alcohol and close the cap.
5. Attach the Alcohol Container to the MU-1's Container Hanger.
6. Insert the Alcohol Container's nozzle into the Water Container Connector on the Light Guide Connector (see Figure 3.6).

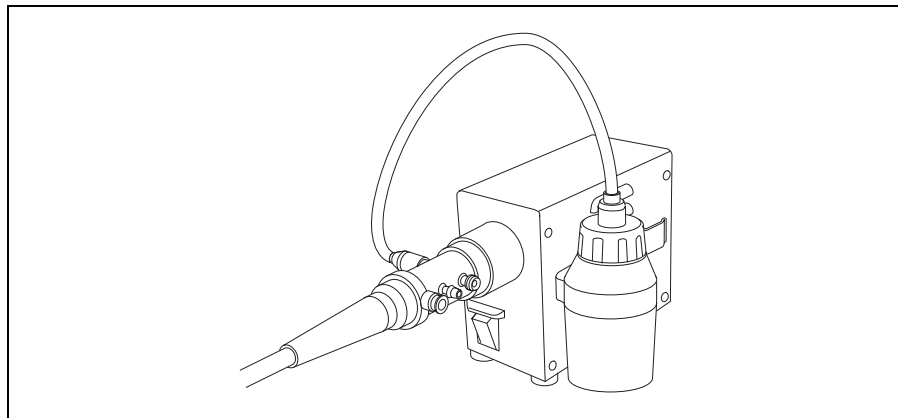

Figure 3.6

# Chapter 4 Operation

The operator of this instrument must be a physician or medical personnel under the supervision of a physician and must have received sufficient training in clinical endoscopic technique. This manual, therefore, does not explain or discuss clinical endoscopic procedures. It only describes basic operation and precautions related to the operation of this instrument.

## **DANGER**

Do not allow the Power Cord to become wet. A wet Power Cord may cause electrical shock.

## **WARNING**

Use personal protective equipment to guard against dangerous chemicals and infectious material. During operation, wear appropriate protective equipment, such as eye wear, a face mask, moisture-resistant clothing and chemical-resistant gloves that fit properly and are long enough so that your skin is not exposed.

## **CAUTION**

Only perform insufflation after drying the channel with 70% ethyl or isopropyl alcohol. Otherwise the 70% ethyl or isopropyl alcohol may remain inside the endoscope's channel.

## 4.1 Leakage Testing

When reprocessing the endoscope, perform leakage testing to ensure that the endoscope is waterproof.

Refer to the instruction manuals of the Leakage Tester and endoscope for directions on Leakage Testing.

## 4.2 Remove water from the Air/Water Channel (For endoscope with Air/Water channel only)

### CAUTION

Do not remove the AW Channel Cleaning Adapter and the Alcohol Container's nozzle until the Power Switch is OFF "○". If the AW Channel Cleaning Adapter or Alcohol Container's nozzle are removed from the endoscope while the Power Switch is ON "I", water or 70% ethyl or isopropyl alcohol will splatter.

### NOTE

Flushing the channels with 70% ethyl or isopropyl alcohol facilitates drying inside the Air/Water channel.

### ***When Irrigating With 70% Ethyl or Isopropyl Alcohol***

1. Turn the Power Switch ON "I".
2. Depress the button on the AW Channel Cleaning Adapter for approximately 10 seconds to irrigate the channel with 70% ethyl or isopropyl alcohol (see Figure 4.1).
3. Release the button and perform insufflation for approximately 10 seconds until no more 70% ethyl or isopropyl alcohol exits the endoscope.
4. Turn the Power Switch OFF "○".
5. Remove the Alcohol Container's nozzle from the Air/Water Port on the Light Guide Connector.
6. Perform drying the Air/Water channel according to the next page.

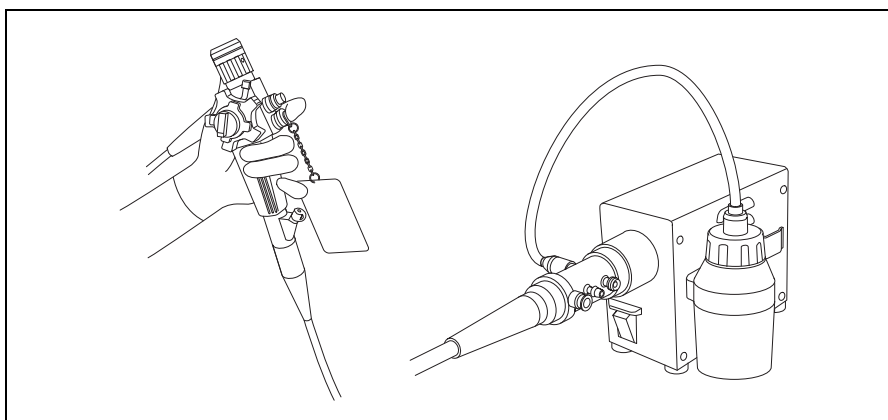

Figure 4.1

## **Dry the Air/Water Channel**

1. Turn the Power Switch ON “ I ”.
2. Close the irrigation port of the endoscope with your finger. Press the AW Channel Cleaning Adapter button and release it. Repeat this procedure at intervals of approximately 30 seconds until no more water or 70% ethyl or isopropyl alcohol exit the Distal End of the endoscope (see Figure 4.2).
3. Turn the Power Switch OFF “ O ”.
4. Remove the Light Guide Connector from the Output Socket.

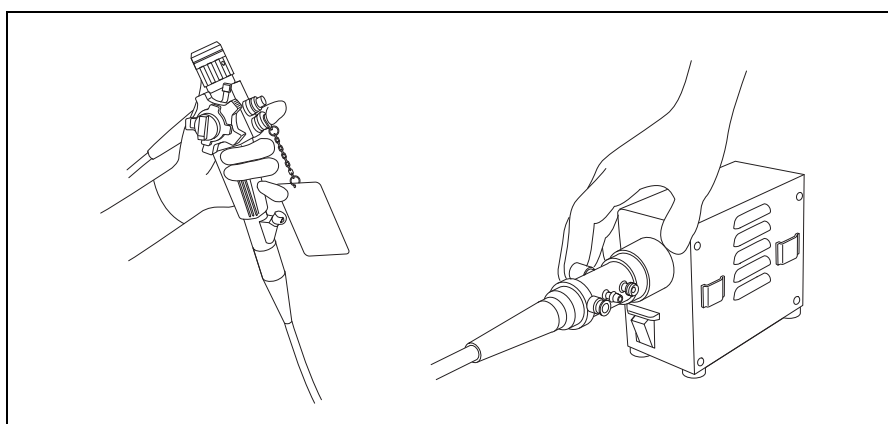

Figure 4.2

# **Chapter 5 Care, Storage and Disposal**

## **5.1 Care**

### **WARNING**

- Use only dry gauze to wipe the Power Switch. Do not moisten the gauze as this could cause the switches to fail, as well as producing an electric shock.
- After wiping with a gauze moistened in liquid, dry the Maintenance Unit thoroughly before using it again. If it is used while still wet, there is risk of electrical shock.
- When performing care of the Maintenance Unit, always wear appropriate personal protection equipment. Blood, mucous and other infection material tuck on the Maintenance Unit could pose an infection control risk.

### **CAUTION**

- Do not steam sterilize (autoclave) or gas sterilize the equipment, the Maintenance Unit will be damaged.
- Do not wipe the outside surface with hard or abrasive wiping material. The surface will be scratched.

If the Maintenance Unit becomes soiled, perform the following cleaning procedure immediately after use. Stains caused by organic substances solidify after a certain amount of time has passed and are very difficult to clean. The equipment should also be cleaned routinely.

1. Turn the Maintenance Unit Power Switch OFF “○” and disconnect the Power Cord.
2. Wipe the equipment using soft, lint-free cloth moistened with 70% ethyl or isopropyl alcohol remove dust, dirt and non-patient debris.
3. Should the equipment become soiled with blood or other potentially infectious materials, first wipe off all gross debris using detergent and then decontaminate the equipment a surface using lint-free cloth moistened with 70% ethyl or isopropyl alcohol. The equipment is compatible with 70% ethyl or isopropyl alcohol.
4. Confirm that the equipment is completely dry before use.



## **5.2 Storage**

### **CAUTION**

Do not store the Maintenance Unit in a location exposed to direct sunlight, X rays, radioactivity or strong electromagnetic radiation (near microwave medical treatment equipment, short-wave medical treatment equipment, MRI equipment or radio). Damage to the Maintenance Unit may result.

Store the equipment in the horizontal position in a clean, dry and stable location.

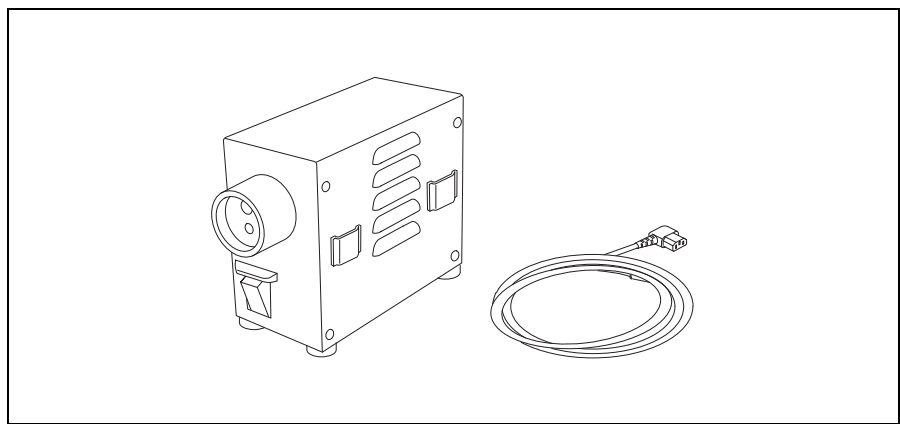

Figure 5.1

## **5.3 Disposal**

When disposing of this product, or any of its components, follow all applicable national laws and guidelines.

# Chapter 6 Troubleshooting

If the instrument is visibly damaged, does not function as expected or is found to have other irregularities during the inspection described in Chapter 3, “Preparation and Inspection”, do not use the instrument. Contact Olympus. Problems that appear not to be malfunctions may be correctable by referring to Section 6.1, “Troubleshooting Guide”. Should you fail to correct the problem even after taking the described remedial action, stop using the instrument and send it to Olympus for repair. Olympus does not repair accessory parts. If an accessory part becomes damaged, contact Olympus to purchase a replacement.

## 6.1 Troubleshooting Guide

<b>Irregularity Description</b>	<b>Possible Cause</b>	<b>Solution</b>
The pump does not work.	The Power Cord is not connected.	Connect the Power Cord to a Wall Mains Outlet.
	The Power Switch is not turned ON.	Turn the Power Switch ON “ I ”.
The pump works but no air comes out.	The endoscope is not correctly connected to the unit.	Connect the endoscope to the unit correctly.
	The unit is not correctly connected to the leakage tester, or the leakage tester is not correctly connected to the endoscope.	Connect the unit to the leakage tester correctly, and connect the leakage tester to the endoscope correctly.
Insufflation pressure is weak.	Air leaks from a connection section.	Confirm no air leaks from any connection section.

## **6.2 Returning the Maintenance Unit for Repair**

### **CAUTION**

Olympus is not liable for any injury or damage which occurs as a result of repairs attempted by non-Olympus personnel.

When returning the Maintenance Unit for repair, include a description of the Maintenance Unit malfunction or damage and the name and telephone number of the individual at your location who is most familiar with the Maintenance Unit problem. Also include a repair purchase order.

### **NOTE**

If a Maintenance Unit accessory (Power Cord, Hook, Screw, Instruction Manual) needs to be replaced, contact Olympus to obtain a new one.

# Appendix

## System Chart

The recommended combinations of equipment and accessories that can be used with this instrument are listed below. New products released after the introduction of this instrument may also be compatible for use in combination with this instrument. For further details, contact Olympus.

**WARNING**

If combinations of equipment other than those shown below are used, the full responsibility is assumed by the medical treatment facility.

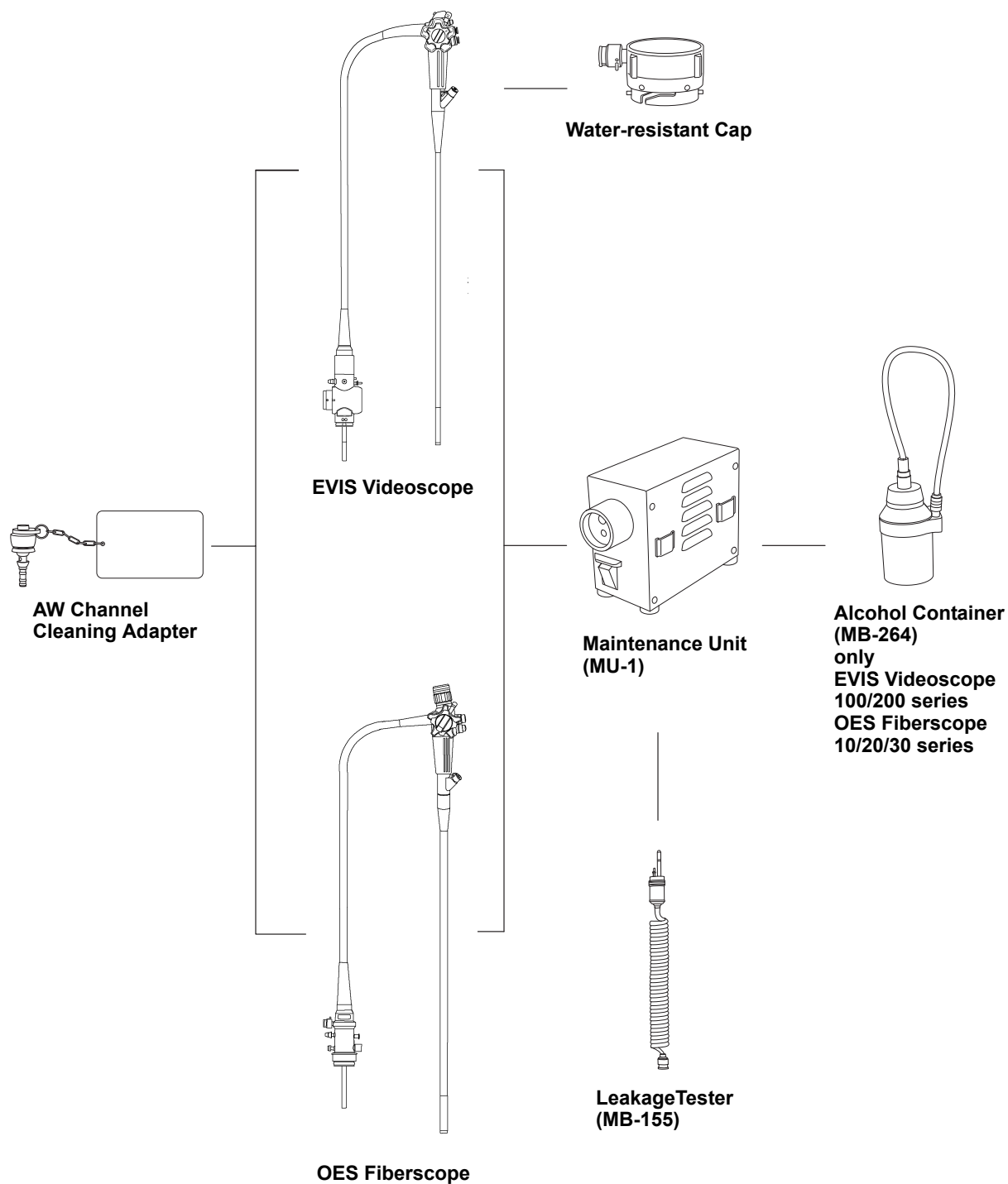

## Transportation, Storage and Operating Environments

<b>Transportation and Storage Environment</b>	<b>Ambient Temperature</b>	-25 to +70°C (-13 to +158°F)
	<b>Relative Humidity</b>	10 - 90%
	<b>Atmospheric Pressure</b>	700 - 1060 hPa
<b>Operating Environment</b>	<b>Ambient Temperature</b>	10 - 40°C (50 to 104°F)
	<b>Relative Humidity</b>	30 - 85%(without condensation)
	<b>Air Pressure</b>	700 - 1060 hPa (0.7 - 1.1 kgf/cm <sup>2</sup> ) (10.2 - 15.4 psia)

## Specifications

	<b>Item</b>	<b>Specification</b>
<b>Power Supply</b>	<b>Voltage</b>	120 V AC
	<b>Voltage Fluctuation</b>	Within ±10%
	<b>Frequency</b>	50/60 Hz
	<b>Frequency Fluctuation</b>	Within ±1 Hz
	<b>Input Current</b>	0.4 A
<b>Size</b>	<b>Dimensions</b>	85 (W) × 157 (H) × 170 (D) mm (maximum)
	<b>Weight</b>	1.8 kg
<b>Compatible Endoscopes</b>		OES Fiberscope EVIS Videoscope
<b>Insufflation function</b>	<b>Pump</b>	Electromagnetic Vibrator
	<b>Performance</b>	At scope socket: 2000 ml/min      1.76 × 10 <sup>4</sup> Pa and higher 0 ml/min          2.84 × 10 <sup>4</sup> Pa and higher

<b>Classification (Medical Electrical Equipment)</b>	<b>Type of Protection against Electric Shock</b>	Class I
	<b>Degree of Protection against Electric Shock of Applied part</b>	TYPE BF
	<b>Degree of Protection against Explosion</b>	This instrument should be kept away from flammable gases
<b>Year of Manufacture</b>	<b>7712345</b> ↑	The last digit of the year of manufacture is the second digit of the serial number.
<b>EMC</b>	<b>Applied standard ; IEC 60601-1-2 : 2001</b>	This instrument complies with the standards listed in the left column.  CISPR 11 of emission : Group 1,Class B  This instrument complies with the EMC standard for medical electrical equipment; edition 2(IEC 60601-1-2 : 2001). However, when connecting to an instrument that complies with the EMC standard for medical electrical equipment; edition 1 (IEC 60601-1-2 : 1993), the whole system complies with edition 1.











©1997 OLYMPUS MEDICAL SYSTEMS CORP. All rights reserved.  
No part of this publication may be reproduced or distributed without the  
express written permission of OLYMPUS MEDICAL SYSTEMS CORP.

OLYMPUS is a registered trademark of OLYMPUS CORPORATION.

Trademarks, product names, logos, or trade names used in this  
document are generally registered trademarks or trademarks of each  
company.



# OLYMPUS®

Manufactured by



## **OLYMPUS MEDICAL SYSTEMS CORP.**

2951 Ishikawa-cho, Hachioji-shi, Tokyo 192-8507, Japan  
Fax: (042)646-2429 Telephone: (042)642-2111

Distributed by

## **OLYMPUS AMERICA INC.**

3500 Corporate Parkway, P.O. Box 610, Center Valley, PA  
18034-0610, U.S.A.  
Fax: (484)896-7128 Telephone: (484)896-5000

## **OLYMPUS LATIN AMERICA, INC.**

5301 Blue Lagoon Drive, Suite 290 Miami, FL 33126-2097, U.S.A.  
Fax: (305)261-4421 Telephone: (305)266-2332



## **OLYMPUS EUROPA SE & CO. KG**

(Premises/Goods delivery) Wendenstrasse 14-18, 20097 Hamburg, Germany  
(Letters) Postfach 10 49 08, 20034 Hamburg, Germany  
Fax: (040)23773-4656 Telephone: (040)23773-0

## **KEYMED (MEDICAL & INDUSTRIAL EQUIPMENT) LTD.**

KeyMed House, Stock Road, Southend-on-Sea, Essex SS2 5QH, United Kingdom  
Fax: (01702)465677 Telephone: (01702)616333

## **OLYMPUS MOSCOW LIMITED LIABILITY COMPANY**

117071, Moscow, Malaya Kaluzhskaya 19, bld. 1, fl.2, Russia  
Fax: (095)958-2277 Telephone: (095)958-2245

## **OLYMPUS (BEIJING) SALES & SERVICE CO., LTD.**

A8F, Ping An International Financial Center, No. 1-3, Xinyuan South Road,  
Chaoyang District, Beijing, 100027 P.R.C.  
Fax: (86)10-5976-1299 Telephone: (86)10-5819-9000

## **OLYMPUS KOREA CO., LTD.**

Olympus Tower 9F, 446, Bongeunsa-ro, Gangnam-gu, Seoul, Korea 135-509  
Fax: (02)6255-3494 Telephone: (02)6255-3210

## **OLYMPUS SINGAPORE PTE LTD**

491B, River Valley Road #12-01/04, Valley Point Office Tower, Singapore 248373  
Fax: 6834-2438 Telephone: 6834-0010

## **OLYMPUS AUSTRALIA PTY LTD**

3 Acacia Place, Notting Hill, VIC 3168, Australia  
Fax: (03)9543-1350 Telephone: (03)9265-5400

